

Ax1



Bx2



Cx2



Dx8



$\phi 6$

Ex8



$\phi 6 \times 25$

Fx1



$\phi 6$

1

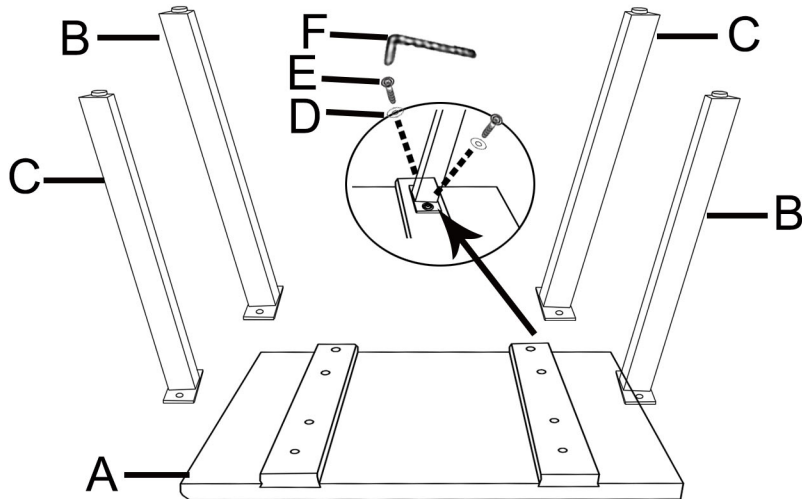

2

